

## AR®Twister | Slider

Galloping and Vibration Control for Lighter-Weight Single Conductors  
Shorter Spans, Optical Ground Wires, Shield Wires  
Smaller Overhead Transmission Lines

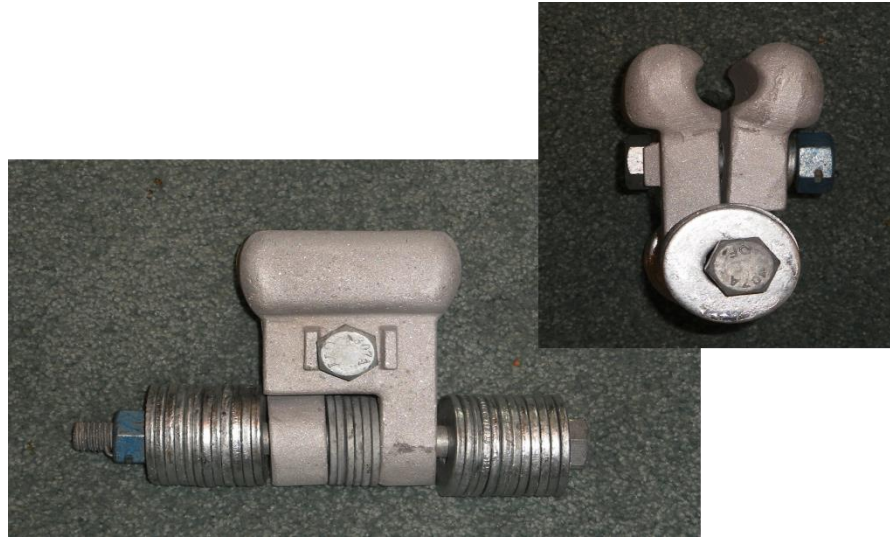

### APPLICATIONS

A vibration control and anti-galloping damper, this solution for lighter-weight lines twists a single conductor, by inertia offset, both statically and dynamically. Vibration control is achieved by allowing the eccentric weight to move against the vibration. By providing an ultra-light weight solution to control galloping on today's lighter-weight conductors and single pole lines, the AR®Twister | Slider can also meet the unique needs of optical ground wires and distribution feeder lines.

Since the severity of the galloping phenomenon is a function of span length, sag, conductor geometry and mechanical properties, each AR®Twister | Slider system is engineered to address the unique features of the line.

### HOW IT WORKS

The AR®Twister | Slider reduces or eliminates galloping of the line by forcing the conductor to twist and unload its aerodynamic lift. It is an inertial device that relies on metal-to-metal friction resulting from small movements between the device's weight and its clamp, thus providing damping sufficient to control high-frequency Aeolian vibrations.

### SPECIFICATIONS

Model	Weight	Conductor	Clamp Sizes	Application
V	4 lbs.	0.625"-0.875"	15/16" to 1-7/16"	Ultra-light-weight conductors
VI	7 lbs.	0.625"-1.80"	15/16" to 1-7/16"	Range of conductors

AR®Twister | Sliders do not hang below the line but are mounted by clamping it vertically above the conductor or at an angle of 45 to 60 degrees below the vertical. Gravity forces make the device want to fall, thereby introducing an initial twist in the conductor. When galloping begins under the critical ice and wind conditions, inertial forces act upon the AR®Twister | Slider causing the conductor to twist against its initial set. Twisting the conductor when there is ice on it, enables the ice shape itself to also dampen; then the twisting of the ice shape acts as an aerodynamic damper. This counter twisting results in unloading of the aerodynamic lift of the ice layer.

**Galloping Control.** Twisting of the conductor is a proven remedy to control galloping. Tests have shown that a small amount of twist - as little as 10 degrees - will reduce gallop amplitudes to harmless levels.

### PERFORMANCE TESTED

AR®Clamps have been strength tested at Helical Line Products. Slipping tests found clamp strength to exceed 1000 lbs.

**CONSTRUCTION**

Fabricated of aluminum throughout, the AR®Twister|Slider may be fitted with corona protection if required. It is available in two models – Large (30 washers) and Small (14 washers); weighing 7 lbs. and 4 lbs. respectively. Intermediate sizes available.

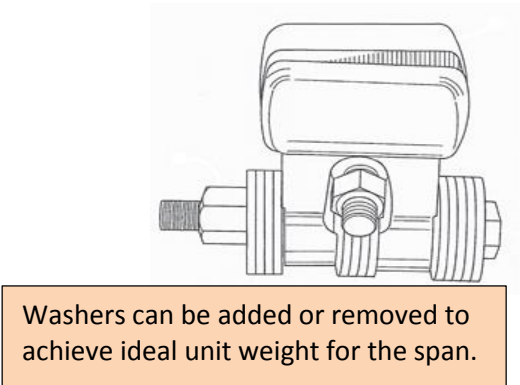
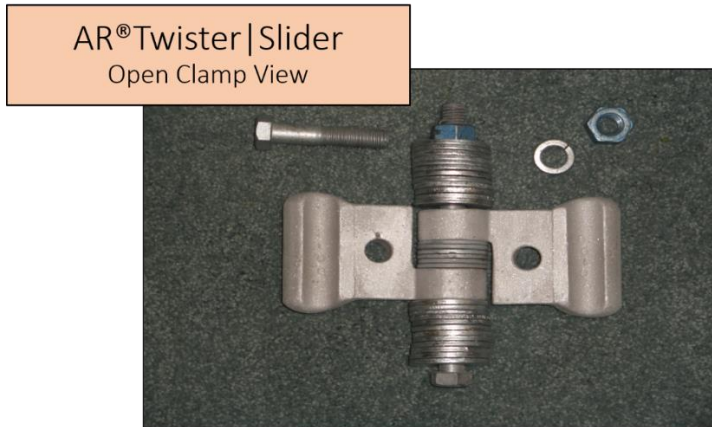

In collaboration with the client’s project engineer, up to 3 models of varying weights can be customized to accommodate span lengths, sag depths and other unique characteristics of the line (span-by-span analysis).

SLIDER MODEL		TOTAL WEIGHT	kv
LARGE	STANDARD	UP TO 7 LBS.	< 230kV
	CORONA PROTECTED		230kV +
SMALL	STANDARD	4 LBS.	< 230kV
	CORONA PROTECTED		230kV +

**Note: The AR Twister|Slider is designed for use with line guards or Armor Rods. Armor Rod specifications will be included in the recommendations for the galloping solution together with specifications for the AR®Twister|Slider model, number of units and placement on the phases of the transmission line.**