



# AR Products

*Solutions for Galloping and Vibration Control*

## AR®Light-Weight Spacer

Galloping Control for Bundled Conductors  
Horizontal and Vertical Transmission Lines



### APPLICATIONS

A gallop control solution for bundled conductors, the AR® Lightweight Spacer (ARLWS) controls galloping on vertical and horizontal lines by twisting the conductor in twin bundles. The ARLWS allows the cable or conductor to twist as it starts to gallop up and down. Twisting is the primary method for galloping control in all AR®Products. In addition to providing a lightweight solution to control galloping for the traditional steel-supported, aluminum conductors, the ARLWS can also meet the unique needs of transmission lines serving wind turbines. The angle-limiting feature of clamps are capable of delivering the same performance as the AR® MOD II Spacer Damper for twin, triple and quad bundles.

AR®Spacer Dampers have been tested at NEETRAC for strength, corona and vibration control. Currently, the ARLWS is available in models with clamp sizes designed for three conductors: Drake, Falcon and Cardinal. The design of the clamp allows scaling for a range of conductor sizes. The AR®Light-Weight Spacers require Armor Rods.

### HOW IT WORKS

**Angle-Limiting Feature.** Articulated clamps rotate and twist the conductor through large angles. The angle-limiting feature prevents the alligator-design AR®Clamp from coming into contact with the stabilizer rod. In the set position, the

AR®Clamp attaches to the stabilizer rod at two flat top extensions end points. The AR®Clamp consists of two elements: the donut and rounded edge alligator-type clamp half are manufactured as a single unit. Two halves are joined with the specified hardware. In the set position, the clamp is installed on the conductor at 60 degrees. As the clamp rotates about a hinge axis, there is a 120 degree range of rotation until the straight corner below the bolt head reaches the maximum when it comes into contact with the flat top. This design eliminates the potential for corona because the nut(s) at both ends of the stabilizer rod remain inside the bundle. The combined range of motion of the two clamps together, enables a wider angle of rotation before the alligator clamp hits the limiting stops. As a result, there is the widest possible angle of total rotation to facilitate a greater twisting ability of the conductor, and therefore greater galloping control.

**Strength.** The donut in the center of the stabilizer rod increases the compressive strength of the unit. By test, it was found that compressive strength exceeds 3,000 lbs.

**Galloping Control.** The large rotation angles effectively change the wind angle of attack during galloping for control purposes, a proven technology and method.

### SPECIFICATIONS

- |                       |   |
|-----------------------|---|
| ▪ Stabilizer Rod      | 12" and 15"   |
| ▪ Articulating Clamps | 5 sizes scaled for conductor sizes with O.D. ranging from 1.0 to 1.65   |
| ▪ Hardware            | Clamp assembly                      2 nut/bolt sets (5/8); washer<br>Clamp/Rod assembly                4 large washers, 4 medium washers, 2 nut/bolt sets |

**CONSTRUCTION**

ARLWS is constructed of aluminum for weight and strength. The smooth outer edges of the AR®Clamps and the recessed placement of hardware guards against corona. The smooth inner edges and flexibility in hardware/Armor Rod choices makes the ARLWS suitable for a range of conductor sizes. For the largest ARLWS (larger AR®Clamp; 15” stabilizer rod) the total weight is less than 13 lbs. Benefits include easier assembly and installation (helicopter or bucket truck), less drag on the conductor, and lower cost.

AR®Clamp for ARLWS

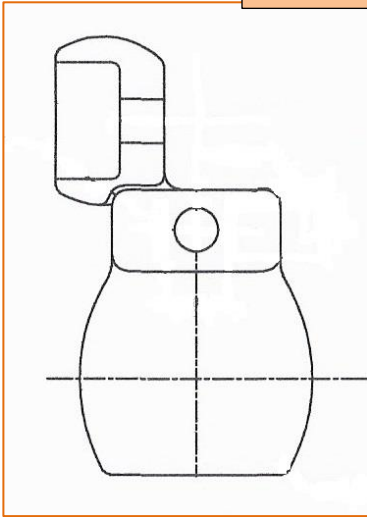

AR®CLAMP SIZE		CONDUCTOR OD RANGE	TOTAL WEIGHT	BAR LENGTHS
EXTRA LARGE	HORIZONTAL	1.50 – 1.65	12.5 LBS.	12”
	VERTICAL			15”
LARGE	HORIZONTAL	1.30 – 1.50	12 LBS.	12”
	VERTICAL			15”
MEDIUM	HORIZONTAL	1.00 – 1.30	10.5 LBS.	12”
	VERTICAL			15”
SMALL	HORIZONTAL	< 1.01	9 LBS.	12”
	VERTICAL			15”

AR®Stabilizer Bar for ARLWS

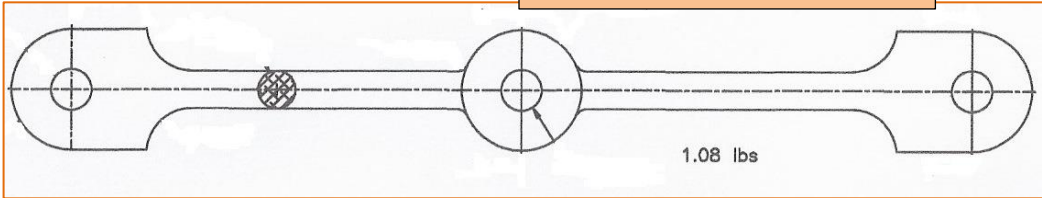

**Note:** The ARLWS is designed for use with Armor Rods. Armor Rod specifications will be included in the recommendations for the galloping solution together with specifications for the appropriately sized ARLWS, number of units and placement on the phases of the transmission line.